

Part Number: PT427-0C080

Kit Contents

Item #	Quantity Req'd.	Description
1	1	Hood protector
2	1	Hardware bag

Hardware Bag Contents

Item #	Quantity Req'd.	Description
1	2	Outside Hood Bracket
2	2	Nylon Insert
3	2	10-24 MS
4	5	Mylar
5	5	Nylon Guide Pin Fasteners
6	2	Breakaway Clips

Additional Items Required For Installation

Item #	Quantity Req'd.	Description
1		

Conflicts

--

Recommended Tools

Personal & Vehicle Protection	Notes
Vehicle Protection	Blanket
Special Tools	Notes
None	
Installation Tools	Notes
Screwdriver	Phillips, #2
Socket	10mm & Extension
Torque Wrench	Dial Type or Digital (0-10 N·m)
Special Chemicals	Notes
Cleaner	Soap and Water

General Applicability

Note: PT427-0C080 is now applicable to the 2010 Tundra as it shares the same grille as 2008-2010 Sequoia. Therefore, install is the same.

Recommended Sequence of Application

Item #	Accessory
1	

*Mandatory

Vehicle Service Parts (may be required for reassembly)

Item #	Quantity Req'd.	Description
1		
2		
3		

Legend

 **STOP:** Damage to the vehicle may occur. Do not proceed until process has been complied with.

 **OPERATOR SAFETY:** Use caution to avoid risk of injury.

 **CAUTION:** A process that must be carefully observed in order to reduce the risk of damage to the accessory/vehicle and to ensure a quality installation.

 **TOOLS & EQUIPMENT:** Used in Figures calls out the specific tools and equipment recommended for this process.

 **REVISION MARK:** This mark highlights a change in installation with respect to previous issue.

 **SAFETY TORQUE:** This mark indicates that torque is related to safety.



Care must be taken when installing this accessory to ensure damage does not occur to the vehicle. The installation of this accessory should follow approved guidelines to ensure a quality installation.

These guidelines can be found in the "Accessory Installation Practices" document.

This document covers such items as:-

- Vehicle Protection (use of covers and blankets, cleaning chemicals, etc.).
- Safety (eye protection, rechecking torque procedure, etc.).
- Vehicle Disassembly/Reassembly (panel removal, part storage, etc.).
- Electrical Component Disassembly/Reassembly (battery disconnection, connector removal, etc.).

Please see your Toyota dealer for a copy of this document.

1. Pre-installation Preparation.



- (a) Inspect and verify the kit contents.
- (b) Make sure front edge of hood, where the deflector is to be installed, is clean and free from dirt and/or debris using soap and water, dry thoroughly.
- (c) Open hood and cover engine bay completely with a protective blanket to catch any dropped hardware.
- (d) Cover front bumper fascia with a blanket.
- (e) Peel masking half way up from the bottom of hood protector.

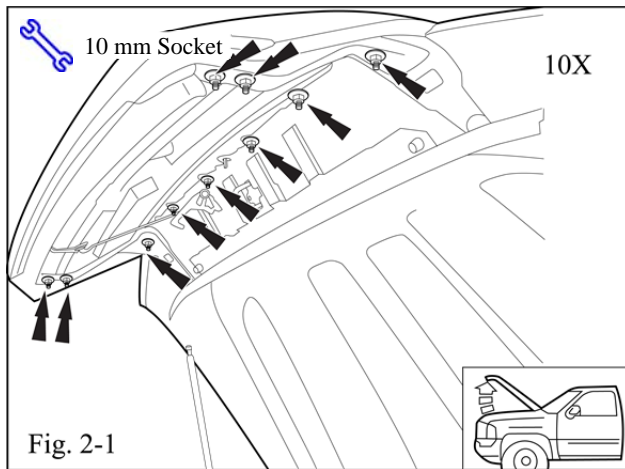

2. Installation.

- (a) With the hood open, and remove ten (10) bolts from the underside of the hood (Fig. 2-1).
- (b) Save the bolts for later use.
- (c) Application of 1 7/8" (48mm) mylar strips to outer bracket locations. (Fig. 2-2) Starting at the top of the hood approx. 15mm from the edge of the hood, wrap the mylar around the edge to the underside of the hood.

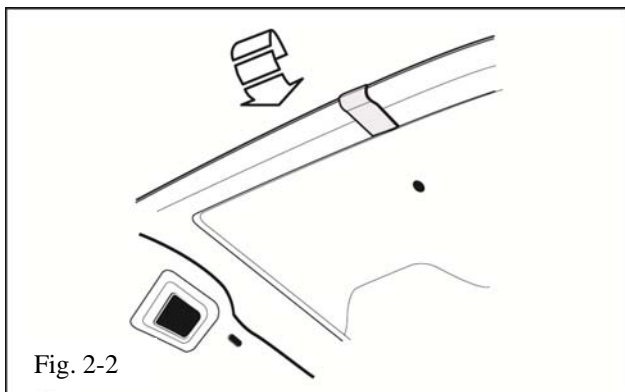

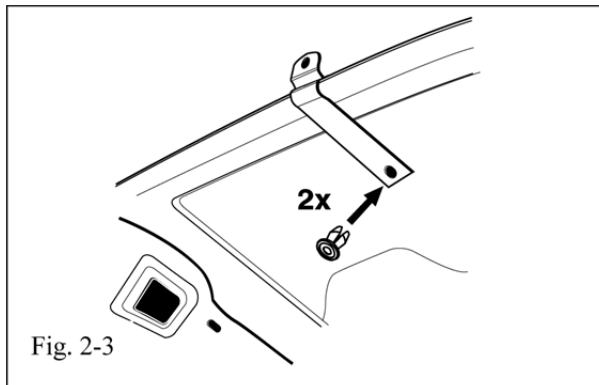

- (d) Attach outer brackets using nylon insert. (Fig. 2-3)

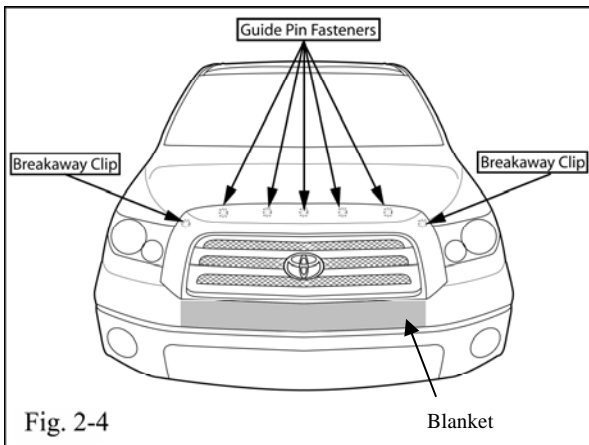

- (e) Partially close the hood in order to separate the grille from the hood, pull on grille to disengage two (2) clips at corner of grille as shown. Then pull on grille to disengage five (5) nylon guide pin fasteners. (Fig 2-4).

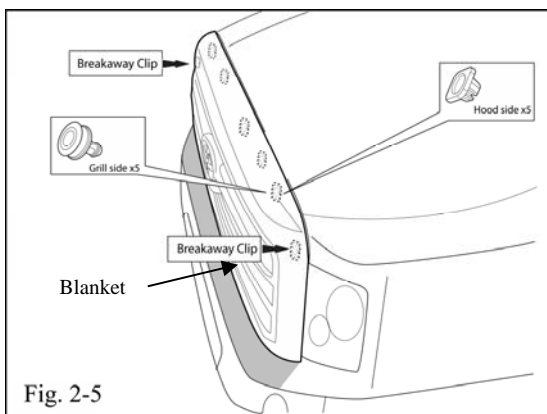

- (f) Confirm that the five (5) yellow Guide Pin Retainers are still present in the outer hood. Also, remove the two (2) breakaway clips and foam washers. (Fig 2-5).

NOTE: Portions of the breakaway clips may fall into the grill and will be unable to be removed. Removal is not necessary if this occurs.

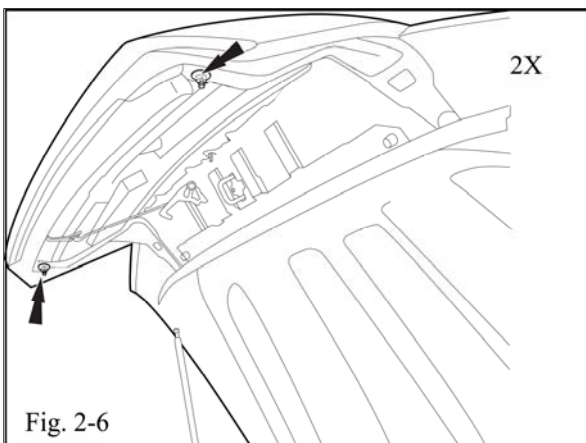

- (g) Raise the hood, loosely install two (2) bolts attaching grille to hood brackets but DO NOT TIGHTEN. This will help hold the grille during hood protector installation. (Fig 2-6).

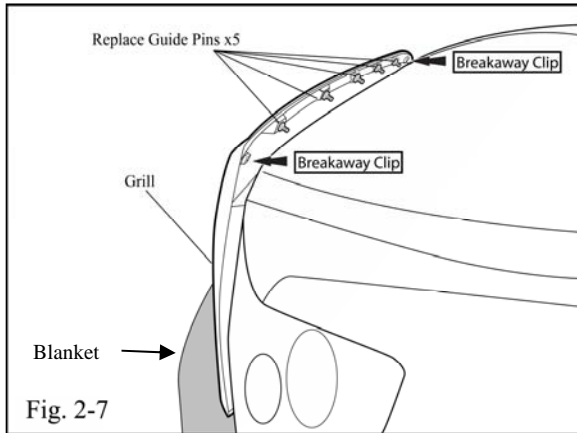

(h) Replace the five (5) existing nylon guide pins with the five (5) guide pins provided within the hardware kit. Also remove the two breakaway clips at the outer corners of the grille and replace with the two (2) clips provided within the hardware kit. Discard the old guide pins and breakaway clips (Fig 2-7).

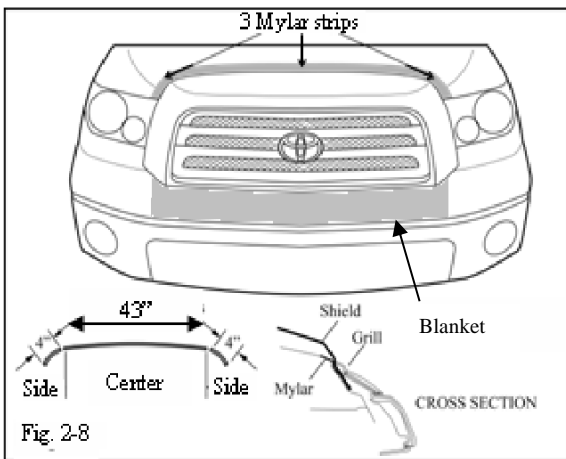

(i) Clean and dry the area thoroughly. Apply 3 mylar strips in between hood and grille, wrap $\frac{1}{2}$ under the hood. Use the 43" (1092mm) strip for the center section, and apply the 4" (102mm) pieces to cover the side area on hood (Fig. 2-8).

(j) Gently slide hood protector into place and center. Be sure the hood protector is fully seated. If additional clearance is needed, pull slightly on the grille to create a larger gap. Take caution not to pull excessively on grille (Fig 2-9).

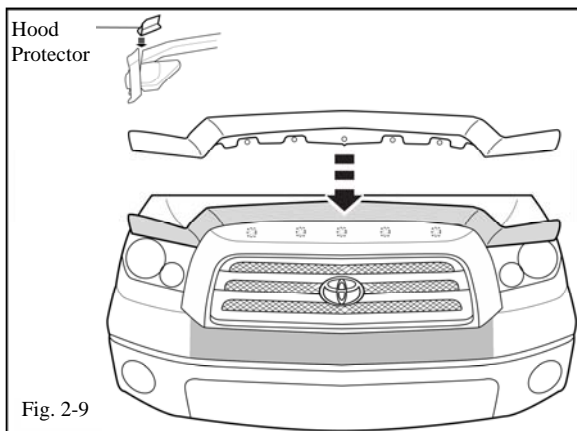

(k) Make sure that the center guide pin is located through the center hole of hood protector and that the hood protector fits properly to the hood and corner of grille (Fig 2-9).

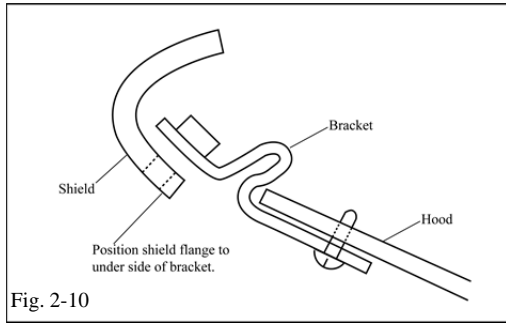

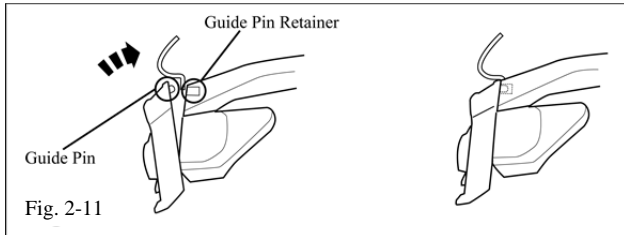

(l) Position the outer hood protector flange underneath the edge of the brackets (Fig 2-10).

(m) Inspect the grille weather strip to ensure that it overlaps the hood protector and the seal lip is not rolled under.

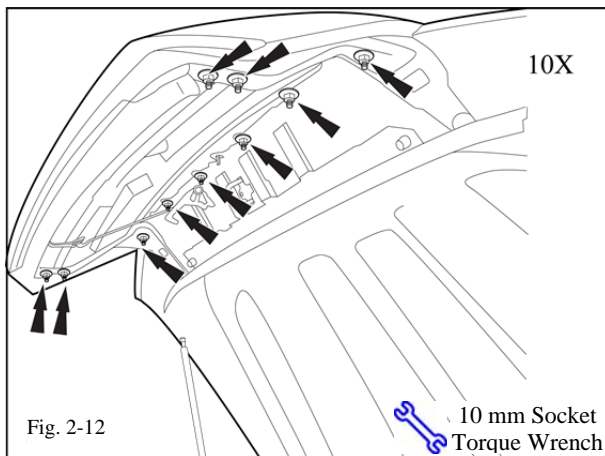

(n) Snap the five (5) guide pins into place by pushing grille into the hood guide pin retainers (Fig 2-11).



 (o) Re-install the eight (8) bolts to hood underside. (Fig 2-12). Tighten all ten (10) bolts to 5.9 N·m (52 in·lbf).

 **Torque: 5.9 N·m (52 in·lbf)**

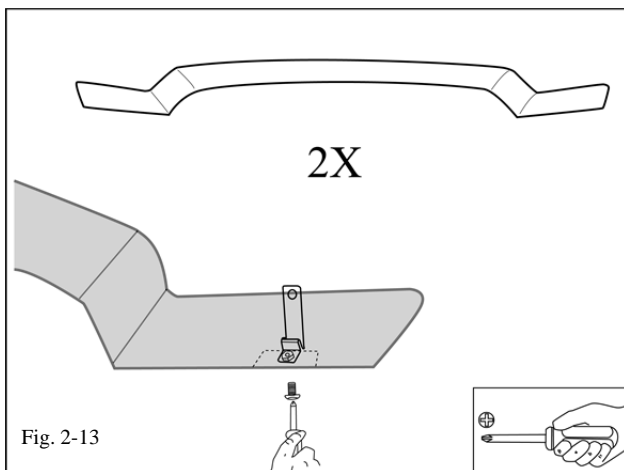

(p) Attach Hood Protector to outer brackets using machine screws. (Fig. 2-13) Hand tighten the screws.

(q) Remove masking tape from the Hood Protector.

(r) Remove blanket on bumper and engine bay.

Checklist - these points **MUST** be checked to ensure a quality installation.

Check:	Look For:
<p><u>Accessory Function Checks</u></p> <p><input type="checkbox"/> Inspect brackets</p> <p><input type="checkbox"/> Mylar Installation</p> <p><input type="checkbox"/> Grille Attachment</p> <p><input type="checkbox"/> Hood Closure</p>	<p><u>Look For:</u></p> <ul style="list-style-type: none"> • Groove in bracket to fit securely along edge of hood. • Mylar strips should not have air bubbles or wrinkles. • Screws attaching brackets to hood protector are firmly tightened. • Brackets must not contact headlights. • Hood Protector should not touch hood surface. • Hood protector side-to-side variation should be within 10mm.
<p><u>Vehicle Appearance Check</u></p> <p><input type="checkbox"/> After accessory installation and removal of protective cover(s), perform a visual inspection.</p>	<p>Ensure no damage (including scuffs and scratches) was caused during the installation process. (For PPO installations, refer to TMS Accessory Quality Shipping Standard.)</p>